

Joint Compensation of CFO and IQ Imbalance in OFDM Receiver: A Deep Learning Based Approach

Siqi Liu, Tianyu Wang, and Shaowei Wang

School of Electronic Science and Engineering, Nanjing University, Nanjing 210023, China
Email: dg1823047@smail.nju.edu.cn, {tianyu.alex.wang, wangsw}@nju.edu.cn

Abstract—Due to the technical and cost limitations, wireless systems suffer from various hardware impairments, including phase noise, power amplifier nonlinearity, carrier frequency offset and in-phase and quadrature-phase imbalance. These impairments can highly degrade the physical layer performance and are usually compensated separately by using model-based signal processing techniques. However, due to the high carrier frequency and large bandwidth of 5G new radio, the coupling effects between different impairments are highly aggravated, which greatly degrades the performance of individual compensation modules for different impairments. In this paper, we propose a deep learning-based method, which jointly addresses the hardware impairments directly from the received data. Specifically, we focus on carrier frequency offset and in-phase and quadrature-phase imbalance, and propose a deep neural network with multiple parallel subnets for joint compensation. Numerical results show that the proposed method outperforms the conventional method using separate compensation modules in practical signal-to-noise ratio regions, and the performance improvement further increases when the cyclic prefix length or the pilot length is limited.

Index Terms—Carrier frequency offset, deep learning, IQ imbalance.

I. INTRODUCTION

Due to the high spectral efficiency property, orthogonal frequency division multiplexing (OFDM) has been widely adopted as the physical layer technology in modern wireless systems, including WiFi, 4G, and 5G networks [1–3]. In OFDM systems, the zero intermediate frequency receiver has been widely adopted for its low complexity and low power consumption. However, its performance can be greatly degraded by radio-frequency (RF) front-end imperfections.

This work was partially supported by the National Natural Science Foundation of China (61801208, 61931023, U1936202).

The RF imperfections may lead to various hardware impairments, including phase noise, power amplifier nonlinearity, carrier frequency offset and in-phase and quadrature-phase imbalance. Traditionally, these impairments are compensated separately by using pilot-aided methods [4]. However, these impairments are fundamentally dependent on each other and their coupling effect may degrade the performance of individual modules. Specifically, for 5G new radio with high carrier frequency and large bandwidth, the coupling effects are further aggravated, and it requires advanced methods to address these impairments jointly. However, joint compensation methods usually suffer from great modeling difficulty and high computational complexity, which highly limits their application in practical systems.

In this paper, we consider two types of hardware impairments, carrier frequency offset (CFO) and in-phase and quadrature-phase (IQ) imbalance. CFO is introduced by the frequency mismatch between the transmitter and the receiver, which causes phase shift and inter-carrier interference. IQ imbalance is introduced by the amplitude distortion and frequency mismatch of the mixers between the I- and Q-branches, which causes serious amplitude and phase distortions. A variety of digital compensation methods are proposed in the literature, including pilot-aided methods [5, 6] and blind methods [7, 8]. However, these methods neglect the coupling effects and may degrade the overall performance. With the presence of IQ imbalance, the phase shift caused by CFO between two consecutive OFDM symbols is no longer a constant, such that the conventional CFO compensation methods using two consecutive pilots are not applicable. Also, a small estimation error of CFO may greatly degrade the performance of IQ imbalance compensation. To address the coupling effect between CFO and IQ imbalance, a number of joint compensation methods are proposed, where the pilots are jointly

designed and processed [9–11].

To overcome the modeling difficulty and high computational complexity of traditional joint compensation methods, we propose a deep learning (DL)-based compensation method for the joint compensation of CFO and IQ imbalance. Recently, DL has been introduced to address signal processing issues in wireless communications [12–15]. In [16], an autoencoder-based transceiver is proposed to learn the end-to-end signal processing to achieve global optimization. In [17], the autoencoder architecture is embedded into an OFDM system to overcome the hardware impairments in terms of power amplifier nonlinearity and CFO, respectively. In [18], a deep neural network (DNN) is proposed as a joint channel estimation and signal detection method and provides comparable performance to the minimum mean-square error algorithm. In [19], an autoencoder-based method is proposed to reduce the peak-to-average-power ratio of OFDM signals, of which the encoder and decoder are utilized as constellation modulation and demodulation, respectively. In [20], a long short-term memory network is connected to a convolutional neural network to directly reconstruct the channel information of time-varying environments. Here, we propose a DNN which jointly compensates the CFO and IQ imbalance and directly recovers information bits from the received data.

The rest of this paper is organized as follows. In Section II, the OFDM receiver with CFO and IQ imbalance is presented. In Section III, the DL-based joint compensation method is proposed. In Section IV, numerical results are provided and analyzed, and Section V concludes the paper.

II. SYSTEM MODEL

We consider an OFDM system with K subcarriers, in which the modulation order is M , the subcarrier interval is Δf and the k -th subcarrier frequency is $f_k = k\Delta f$. The length of an OFDM symbol is then given by $T_s = 1/\Delta f$. We denote by $X[k]$ as the signal transmitted at the k -th subcarrier, and the baseband signal $x(t)$ in time domain is then given by

$$x(t) = \frac{1}{K} \sum_{k=0}^{K-1} X[k] e^{j2\pi f_k t}. \quad (1)$$

When the carrier frequency of the receiver is strictly identical to the transmitter and I- and Q-branches are strictly balanced, the received baseband signal in the

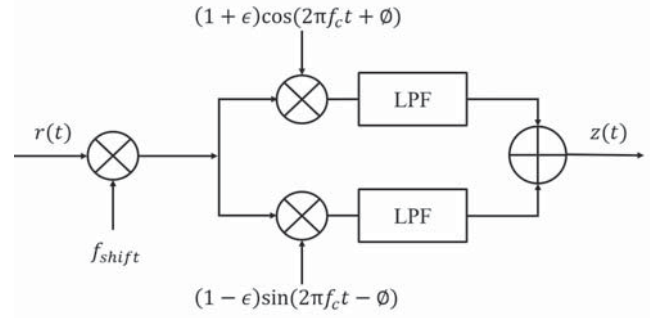

Fig. 1. System model of OFDM receivers with the presence of CFO and IQ imbalance.

time domain can be given by

$$y(t) = \int_{-\infty}^{\infty} x(t - \tau) h(\tau) d\tau + w(t), \quad (2)$$

where $h(\tau)$ and $w(t)$ represent the time domain channel response and the white gaussian noise, respectively.

In Fig. 1, we show an OFDM receiver with the presence of CFO and IQ imbalance. $r(t)$ is the radio frequency signal directly received from the antenna with carrier frequency f_c . $z(t)$ is the signal after the down-conversion. The frequency shift is given by f_{shift} and the amplitude and phase mismatch of the mixers on the I- and Q-branches are given by ϵ and ϕ , respectively. Thus, we have

$$r(t) = y(t) e^{j2\pi f_c t}, \quad (3)$$

and

$$z(t) = LPF\{r(t)(1 + \epsilon)\cos[2\pi(f_{shift} + f_c)t + \phi] + r(t)(1 - \epsilon)\cos[2\pi(f_{shift} + f_c)t - \phi]\}, \quad (4)$$

where $LPF\{\}$ represents the low-pass filter. By substituting (3) into (4), we have

$$\begin{aligned} z(t) &= (1 + \epsilon)\cos\phi Re[y(t)e^{j2\pi f_{shift}t}] \\ &\quad - (1 + \epsilon)\sin\phi Im[y(t)e^{j2\pi f_{shift}t}] \\ &\quad - j(1 - \epsilon)\sin\phi Re[y(t)e^{j2\pi f_{shift}t}] \\ &\quad + j(1 - \epsilon)\cos\phi Im[y(t)e^{j2\pi f_{shift}t}] \\ &= (\cos\phi + j\epsilon\sin\phi)y(t)e^{j2\pi f_{shift}t} \\ &\quad + (\epsilon\cos\phi - j\sin\phi)y^*(t)e^{-j2\pi f_{shift}t}, \end{aligned} \quad (5)$$

where $Re[\cdot]$ and $Im[\cdot]$ represent the real part and the imaginary part of the signal, respectively.

We define two IQ imbalance distortion parameters α and β as follows.

$$\alpha = \cos\phi + j\epsilon\sin\phi, \quad (6)$$

$$\beta = \epsilon \cos \phi - j \sin \phi. \quad (7)$$

Thus, the baseband signal $z(t)$ can be rewritten as

$$z(t) = \alpha y(t) e^{j2\pi f_{shift} t} + \beta y^*(t) e^{-j2\pi f_{shift} t}. \quad (8)$$

The received baseband signal $z(t)$ is then sent to the FFT demodulator. The output signal of the k -th subcarrier is then given by

$$z[K] = \frac{1}{K} \sum_{k=0}^{K-1} z(t) e^{-j2\pi f_k t}. \quad (9)$$

If there is no CFO, i.e., $f_{shift} = 0$, the baseband signal $z(t)$ is given by,

$$z(t) = \alpha y(t) + \beta y^*(t). \quad (10)$$

The baseband signal $z(t)$ consists of two signal components, $\alpha y(t)$ and $\beta y^*(t)$. The former component $\alpha y(t)$ equals the ideally received signal $y(t)$ multiplied by distortion parameter α , which can be easily compensated by channel equalization. The latter component $\beta y^*(t)$ is an interference signal, which is the conjugate of the ideally received $y(t)$ multiplied by distortion parameter β . This mirror interference can be estimated by using conjugate symmetric pilot sequences, as in conventional IQ imbalance compensation methods [6].

If the IQ imbalance can be perfectly compensated, i.e., $\alpha = 1$ and $\beta = 0$, the baseband signal is given by,

$$z(t) = y(t) e^{j2\pi f_{shift} t}. \quad (11)$$

As we can see, the CFO introduces frequency shift f_{shift} in frequency domain, which is equal to phase shift $2\pi f_{shift} t$. Thus, the phase shift between two consecutive OFDM symbols is constant, which can be utilized to estimate the phase shift by inserting identical pilot sequences in the time domain as in the conventional CFO compensation methods [5, 21].

However, with the presence of both CFO and IQ imbalance, the phase shift between two consecutive OFDM symbols resulted by CFO is no longer a constant and the interference caused by the IQ imbalance is no longer a conjugate of the ideally received signal. Therefore, the existing compensation methods that separately compensate CFO and IQ imbalance may suffer from severe performance degradation if the coupling effect is further aggravated as in 5G new radio with high carrier frequency and large bandwidth.

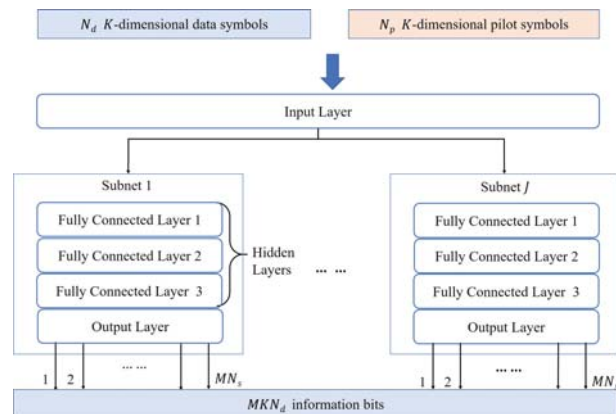

Fig. 2. The proposed DNN model for joint compensation of CFO and IQ imbalance.

III. DEEP LEARNING BASED JOINT COMPENSATION OF CFO AND IQ IMBALANCE

In this section, we utilize a single DNN to jointly compensate the CFO and IQ imbalance. The input is the OFDM symbols representing both the pilot and the data information. The output is the demodulated information bits of the corresponding data symbols. The DNN is trained offline and deployed online at the receiver after the FFT demodulator.

A. Deep Learning Model

As shown in Fig. 2, the proposed DNN has a parallel architecture with J subnets of identical structure and parameters, each of which contains three fully connected hidden layers. The activation function is uniformly given by the rectified linear unit (ReLU) function. All subnets share the same input layer, consisting of N_p pilot symbols and N_d data symbols. The input layer corresponds to $K(N_p + N_d)$ complex modulation signals, which are divided into real and imaginary parts for convenience. Thus, the number of neurons in the input layer is given by $2K(N_p + N_d)$. The output layer of each subnet consists of MN_s neurons, where M is the modulation orders and $N_s = kN_d/J$ is the number of subcarriers addressed by each subnet. The total number of output neurons is then given by MKN_d . The numbers of neurons in hidden layers are set at $2K(N_p + N_d)$, $4K(N_p + N_d)$ and $2K(N_p + N_d)$.

The parallel architecture greatly reduces the number of network parameters and highly reduces the training complexity, while the cost is the loss of correlation information between data in different subnets.

B. Training Process

The training set consists of I samples, in which the i -th sample is given by $(\mathbf{x}_i, \mathbf{y}_i)$, where \mathbf{x}_i represents N_p pilot symbols and N_d data symbols, and \mathbf{y}_i represents the information bits corresponding to the data symbols.

Then, we denote by $\mathbf{u}^{(l)}$ and $\mathbf{W}^{(l)}$ as the states of neurons in the l -th layer and the weight matrix between the l -th and $(l-1)$ -th layers, respectively, and we have

$$\mathbf{u}^{(l)} = f^{(l)}(g^{(l)}(\mathbf{u}^{(l-1)}, \mathbf{W}^{(l)})), \quad (12)$$

where $f^{(l)}(\cdot)$ is the ReLU activation function, given by

$$f^{(l)}(z) = \max(0, z), \quad (13)$$

and $g^{(l)}(\cdot)$ is the linear combination, given by

$$g^{(l)}(\mathbf{u}^{(l)}, \mathbf{W}^{(l)}) = \mathbf{W}^{(l)}\mathbf{u}^{(l)}, \quad (14)$$

Thus, for any input \mathbf{x}_i , the output $\hat{\mathbf{y}}_i$ is given by

$$\hat{\mathbf{y}}_i = f^{(3)}(g^{(3)}(f^{(2)}(g^{(2)}(f^{(1)}(g^{(1)}(\mathbf{x}_i, \mathbf{W}^{(1)})), \mathbf{W}^{(2)})), \mathbf{W}^{(3)})). \quad (15)$$

The loss function is defined as the average mean squared error between $\hat{\mathbf{y}}_i$ and \mathbf{y}_i of all samples, which is given by

$$L = \sqrt{\frac{1}{I} \sum_{i=1}^I \|\hat{\mathbf{y}}_i - \mathbf{y}_i\|^2}, \quad (16)$$

In order to minimize the loss function, the weight parameters are updated by using the backpropagation algorithm. The change of weight parameters in the l -th layer is then given by

$$\Delta \mathbf{W}^{(l)} = -\eta \frac{\partial L}{\partial \mathbf{W}^{(l)}}, \quad (17)$$

where η is the learning rate and $\partial L / \partial \mathbf{W}^{(l)}$ can be calculated by using the chain rule. The updated weight parameters are then given by

$$\mathbf{W}'^{(l)} = \mathbf{W}^{(l)} + \Delta \mathbf{W}^{(l)}. \quad (18)$$

IV. NUMERICAL RESULTS

In this section, experiments are conducted to demonstrate the performance of the proposed method. We set the number of subcarriers $K = 64$, subcarrier frequency $\Delta f = 15\text{kHz}$, OFDM symbol duration $T_s = 66.67\mu\text{s}$, and adopt 8 phase-shift keying modulation, i.e., $M = 3$. The input of the proposed DNN corresponds to one pilot symbol and one data symbol, i.e., $N_p = 1$ and $N_d = 1$, consisting of $K(N_p + N_d) = 128$ complex signals. Thus, the number of neurons in the input layer is $2K(N_p + N_d) = 256$. We set the number of parallel

structures is $J = 8$. Thus, the number of neurons of the output layer in each subnet is $MN_s = 24$. For the network training phase, we set the batch size as 128, the number of epochs as 500, and the learning rate as $\eta = 0.04$. To generate the training sample, the CFO varies between 100 and 200 parts per million randomly, while the IQ imbalance distortion parameter ϵ and ϕ are distributed in $[0.05, 0.1]$ and $[12^\circ, 18^\circ]$, respectively.

We compare the proposed DL-based method with the conventional method using three consecutive pilot symbols followed by three consecutive data symbols [10], where the CFO is estimated based on the phase error characteristics of all the three pilots, and the IQ imbalance parameters are estimated by using the first pilot and the third pilot. The channel estimation and equalization modules utilize the least square and the zero-forcing algorithms, respectively. We conduct the experiments under two scenarios, the AWGN channel and the multipath channel. For the multipath channel, the number of paths is 6, the delay is given by $[0, 3, 4, 7, 12, 14] \mu\text{s}$, and the power attenuation for each path is given by $[-4.437, -8.861, -10.458, -12.219, -18.861, -20.000]\text{dB}$ for each path.

A. AWGN Channel

In Fig. 3, we compare the proposed method with the conventional method with different CP lengths over AWGN channels. The pilot length is fixed at $K_p = 64$. As we can see, the proposed method outperforms the conventional method for SNRs between 0dB and 35dB. As the CP length T_τ is reduced from $T_s/4$, $T_s/8$, to 0, the SNR threshold where the BER of the proposed method surpasses the conventional method increases, which implies that the performance advantage of the proposed method is increased by the reduced CP length.

In the conventional method, the BER slightly increases as the CP length is reduced. The reason is that the reduced CP length decreases the phase shift between two consecutive symbols, and the noise influence is relatively increased. However, in the proposed method, the BER decreases as the CP length is reduced. For the reason that the time interval between the two consecutive symbols decreases as the CP length is reduced, and the time domain correlation between the pilot symbol and the data symbol increases, which helps the compensation of CFO and IQ imbalance.

In Fig. 4, we compare the proposed method with the conventional method with different pilot lengths over AWGN channels. The CP length is fixed at $T_\tau = T_s/4$. As we can see, the BER of the proposed method

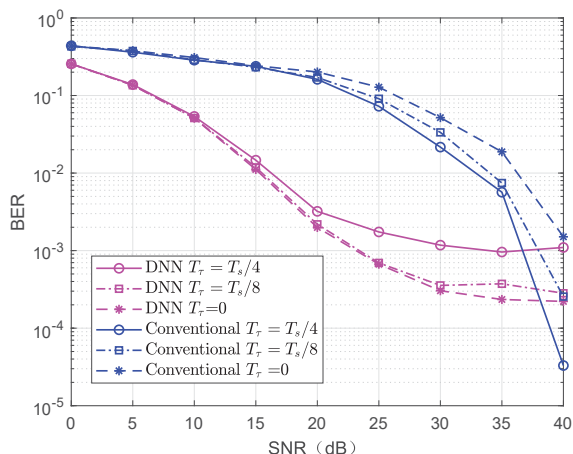

Fig. 3. The BER performance of the proposed and the conventional method with different CP lengths over AWGN channels. The pilot length is $K_p = 64$.

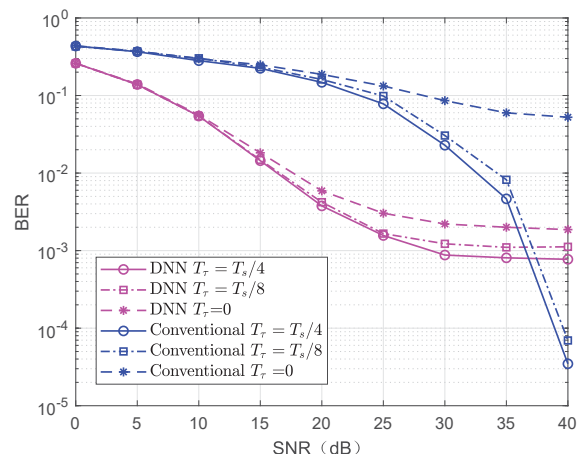

Fig. 5. The BER performance of the proposed and the conventional method with different CP lengths over multipath channels. The pilot length is $K_p = 64$.

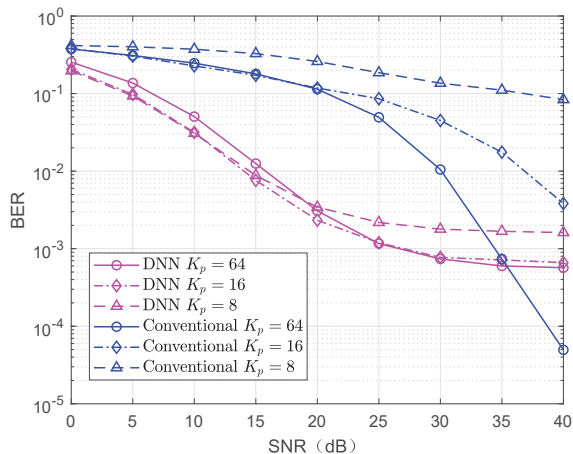

Fig. 4. The BER performance of the proposed and the conventional method with different pilot lengths over AWGN channels. The CP length is $T_\tau = T_s/4$.

outperforms the conventional method for SNRs between 0dB and 35dB. As the pilot length is reduced from 64, 16, to 0, the SNR threshold increases, which implies that the advantage of the proposed method is increased by the reduced pilot length. We can also see that the BER performance increase with the pilot length for both the proposed and the conventional methods since longer pilot sequences increase the estimation accuracy.

B. Multipath Channel

In Fig. 5, we compare the proposed method with the conventional method with different CP lengths over multiple channels, where the pilot length is fixed at $K_p =$

64. When the CP length T_τ is reduced from $T_s/4$, $T_s/8$, to 0, the BER of the proposed method outperforms the conventional method for SNRs between 0dB and 35dB and the SNR threshold where the BER of the proposed method surpasses the conventional method increases. As the CP length is reduced to 0, the conventional method cannot work due to severe inter-subcarrier interference.

As the CP length is reduced, the BER of the proposed method increases, which is different from the AWGN channel where the BER increases. The reason is that even though the CP weakens the time domain correlation between consecutive symbols, it greatly helps to overcome the inter-subcarrier interference introduced by the multipath channel, which can dramatically degrade the demodulation performance. Thus, enough length of CP is important for both of the proposed and the conventional methods over multipath channels.

In Fig. 6, we compare the proposed method with the conventional method with different pilot lengths, where the CP length is fixed at $T_\tau = T_s/4$. As we can see, the proposed method outperforms the conventional method for SNRs between 0dB and 35dB. As the pilot length is reduced from 64, 16, to 0, the SNR threshold increases, which implies that the advantage of the proposed method is increased by the reduced pilot length. For similar reasons in Fig. 4, we can see that the BER performance is improved for both of the proposed method and the conventional method as the pilot length is increased.

In sum, the proposed method outperforms the conventional method for SNRs between 0dB and 35dB. When the CP length or pilot length is reduced, the performance

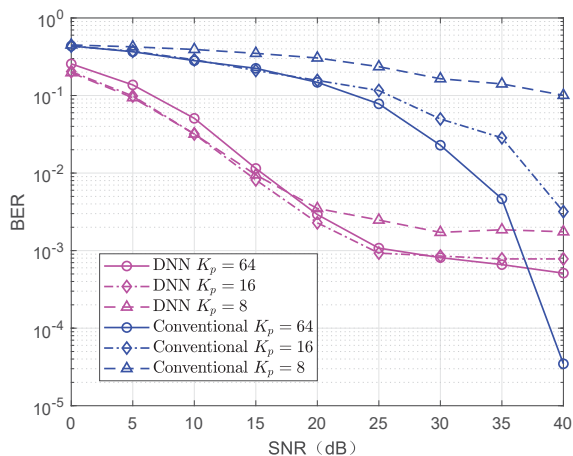

Fig. 6. The BER performance of the proposed and the conventional method with different pilot lengths over multipath channels. The CP length is $T_\tau = T_s/4$.

advantage of the proposed method is increased.

V. CONCLUSION

In this paper, we have proposed a DL-based method for the joint compensation of CFO and IQ imbalance in OFDM receivers. Compared with the conventional compensation method using two separate modules for each impairment, the proposed method directly recovers the information bits from the received signals by using a single DNN. Numerical results show that the proposed method achieves a lower BER than the conventional method for SNRs between 0dB and 35dB, and the BER improvement further increases when the CP length or the pilot length is limited.

REFERENCES

- [1] S. Wang, W. Shi, and C. Wang, "Energy-efficient resource management in OFDM-based cognitive radio networks under channel uncertainty," *IEEE Trans. Commun.*, vol. 63, no. 9, pp. 3092–3102, Sep. 2015.
- [2] X. Sun and S. Wang, "Resource allocation scheme for energy saving in heterogeneous networks," *IEEE Trans. Wireless Commun.*, vol. 14, no. 8, pp. 4407–4416, Aug. 2015.
- [3] S. Wang, M. Ge, and W. Zhao, "Energy-efficient resource allocation for ofdm-based cognitive radio networks," *IEEE Trans. Commun.*, vol. 61, no. 8, pp. 3181–3191, Aug. 2013.
- [4] T. C. W. Schenk and E. R. Fledderus, "RF Impairments in High-Rate Wireless Systems - Understanding the Impact of TX/RX-Asymmetry," in *Proc. ISCCSP'08*, St Julians, Malta, Mar. 2008.
- [5] J. Li, G. Liu, and G. B. Giannakis, "Carrier Frequency Offset Estimation for OFDM-Based WLANs," *IEEE Signal Process. Lett.*, vol. 8, no. 3, pp. 80–82, Mar. 2001.
- [6] L. He, S. Ma, Y. Wu, Y. Zhou, T. Ng, and H. V. Poor, "Pilot-Aided IQ Imbalance Compensation for OFDM Systems Operating Over Doubly Selective Channels," *IEEE Trans. Signal Process.*, vol. 59, no. 5, pp. 2223–2233, 2011.
- [7] L. Wu, X. Zhang, P. Li, and Y. Su, "A Closed-Form Blind CFO Estimator Based on Frequency Analysis for OFDM Systems," *IEEE Trans. Commun.*, vol. 57, no. 6, pp. 1634–1637, 2009.
- [8] M. Matsui, T. Nakagawa, R. Kudo, K. Ishihara, and M. Mizoguchi, "Blind Frequency-Dependent IQ Imbalance Compensation Scheme Using CMA for OFDM System," in *Proc. IEEE PIMRC'11*, Toronto, ON, Canada, Sep. 2011.
- [9] F. Yan, W. Zhu, and M. Omair Ahmad, "Carrier Frequency Offset Estimation for OFDM Systems with I/Q Imbalance," in *Proc. MWSCAS'04*, Hiroshima, Japan, Jul. 2004.
- [10] S. D. Rore, E. Lopez-Estraviz, F. Horlin, and L. V. Der Perre, "Joint Estimation of Carrier Frequency Offset and IQ Imbalance for 4G Mobile Wireless Systems," in *Proc. IEEE ICC'06*, Istanbul, Turkey, Jun. 2006.
- [11] H. Oka, C. Ahn, T. Omori, and K. Hashimoto, "IQ Imbalance and Carrier Frequency Offset Compensation Schemes for TFI-OFDM," in *Proc. ISPACS'14*, Kuching, Malaysia, 2014.
- [12] O. Simeone, "A Very Brief Introduction to Machine Learning With Applications to Communication Systems," *IEEE Trans. Cogn. Commun. Netw.*, vol. 4, no. 4, pp. 648–664, Dec. 2018.
- [13] Z. Kuai and S. Wang, "Thompson Sampling-Based Antenna Selection With Partial CSI for TDD Massive MIMO Systems," *IEEE Trans. Commun.*, vol. 68, no. 12, pp. 7533–7546, 2020.
- [14] W. Yu, T. Wang, and S. Wang, "Multi-Label Learning Based Antenna Selection in Massive MIMO Systems," *IEEE Trans. Veh. Technol.*, early access, 10.1109/TVT.2021.3087132, 2021.
- [15] T. Wang and S. Wang, "Online Convex Optimization for Efficient and Robust Inter-Slice Radio Resource Management," *IEEE Trans. Commun.*, early access, 10.1109/TCOMM.2021.3087127, 2021.
- [16] T. J. O'Shea and J. Hoydis, "An Introduction to Deep Learning for the Physical Layer," *IEEE Trans. on Cogn. Commun. Netw.*, vol. 3, no. 4, pp. 563–575, Dec. 2017.
- [17] A. Felix, S. Cammerer, S. Dörner, J. Hoydis, and S. Ten Brink, "OFDM-Autoencoder for End-to-End Learning of Communications Systems," in *Proc. IEEE SPAWC'18 Wkshps*, Kalamata, Greece, Jun. 2018.
- [18] H. Ye, G. Y. Li, and B. Juang, "Power of Deep Learning for Channel Estimation and Signal Detection in OFDM Systems," *IEEE Commun. Lett.*, vol. 7, no. 1, pp. 114–117, Feb. 2018.
- [19] M. Kim, W. Lee, and D. Cho, "A Novel PAPR Reduction Scheme for OFDM System Based on Deep Learning," *IEEE Commun. Lett.*, vol. 22, no. 3, pp. 510–513, Mar. 2018.
- [20] T. Wang, C. Wen, S. Jin, and G. Y. Li, "Deep Learning-Based CSI Feedback Approach for Time-Varying Massive MIMO Channels," *IEEE Wireless Commun. Lett.*, vol. 8, no. 2, pp. 416–419, Apr. 2019.
- [21] P. H. Moose, "A Technique for Orthogonal Frequency Division Multiplexing Frequency Offset Correction," *IEEE Trans. Commun.*, vol. 42, no. 10, pp. 2908–2914, 1994.